

NEW

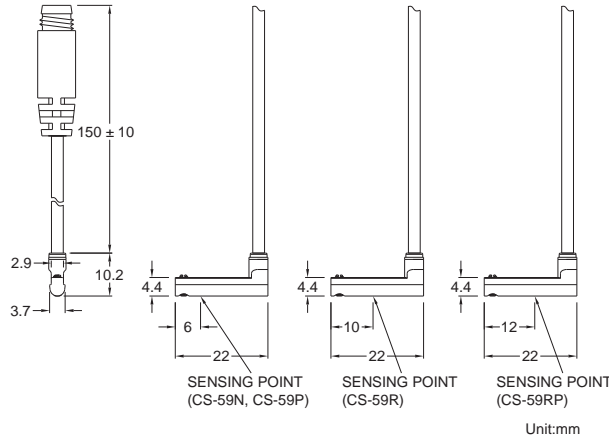

■ DIMENSIONS

CS-59R, CS-59N, CS-59P, CS-59RP / CS-59R-QD, CS-59N-QD, CS-59P-QD, CS-59RP-QD



Unit:mm

■ QD PINOUT

*3 wire QD wiring

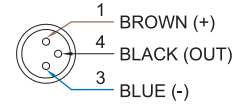

*2 wire QD wiring

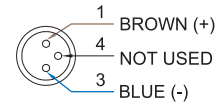

*2 wire EQD wiring

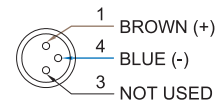

■ SPECIFICATIONS

TYPE	CS-59R	CS-59N	CS-59P	CS-59RP
CONNECT DIAGRAM				
CHARACTERISTICS				
Wiring Method	2-Wire Type	3-Wire Type		
Switching Logic	SPST, Normally Open	Solid State Output, Normally Open		SPST, Normally Open
Sensor Type	Reed Switch	NPN Current Sinking	PNP Current Sourcing	Reed Switch
Operating Voltage	5~120V DC/AC	10~30V DC		10~30V DC/AC
Switching Current	100mA max.	200mA max.		500mA max.
Contact Rating (*1)	10W max.	6W max.		10W max.
Current Consumption	-	10mA @ 24V DC max.		5mA @ 24V DC max.
Voltage Drop	3.5V max.	0.5V @ 50mA max.		0.1V @ 100mA max.
Leakage Current	-	0.01mA max.		-
Indicator	Red LED		Yellow LED	
Cable	ø2.5, 2C, PUR		ø2.5, 3C, PUR	
Operating Frequency	200Hz	1000Hz		200Hz
Magnet Requirement (*2)	70Gauss	40Gauss		50Gauss
Temperature Range	-10~70°C (+14~158°F)			
Shock (*3)	30G	50G		30G
Vibration (*4)	9G			
Enclosure Classification	IEC 60529 IP67 (NEMA 6)			
Protection Circuit (*5)	1	3,4		1

NOTE:

1. WARNING: Never exceed rating (Watt=Voltage x Amperage). Permanent damage to sensor will occur.
2. Measuring standard target: ø15.5xø8X5t (Anisotropy rubber magnet)
3. Sin wave / X, Y, Z 3 directions / 3 times each direction / 11 ms each time.
4. Double amplitude 1.5 mm / 10Hz~55Hz~10Hz (Sweep 1 min) / X, Y, Z 3 directions / 1 hour each time.
5. 1=None / 2=Short-circuit / 3=Power Source Reverse polarity / 4=Surge Suppression

■ GROOVE DIMENSIONS

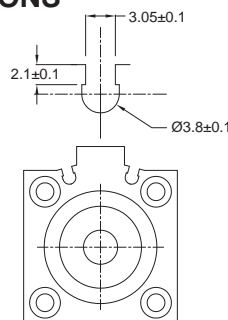

Unit:mm